

# **QUANTITY GAUGE MEASUREMENT SIGNAL SENDING UNIT SSU-33/240-M**



## **CALIBRATION & OPERATION MANUAL**

# TABLE OF CONTENTS

<u>Section</u>	<u>Description</u>	<u>Page</u>
1.0	DESCRIPTION .....	3
2.0	OPERATING THEORY .....	3
3.0	SPECIFICATIONS .....	3
4.0	INITIAL SET-UP .....	4
5.0	WIRING.....	4
6.0	CALIBRATION .....	4~6
7.0	TROUBLESHOOTING .....	7~8
8.0	ASSISTANCE .....	8
9.0	WARRANTY AND PARTS .....	8
10.0	MECHANICAL AND HOOK-UP DRAWINGS .....	9~10

## 1.0 DESCRIPTION

The Model SSU 33/240 is a signal conversion, level sending unit. The device interprets the measurement signal received from the probe, converts the liquid-level measurement to a compatible milliamp signal which can be displayed using a common 33~240 ohm automotive-type FUEL gauge.

## 2.0 OPERATING THEORY

The module utilizes analog & digital technology to precisely monitor the probe condition. The design will accommodate calibration for the 60 GAL or 100 GAL probes. The calibration compensates for the different probe characteristic capacitance.

The EMPTY-TANK calibration represents the EMPTY (0%) point of the probe. The FULL calibration represents the FULL-TANK conditions. Installation calibration is required, to compensate for probe installation, cable length etc.

The device incorporates a 20KHZ signal to the probe. The signal is approximately 3 volts in amplitude, and is AC coupled to the probe. The AC coupling limits the current to the probe and isolates the probe from any DC voltage or supply bias. The design takes into consideration intrinsic-safety practices by supplying Low-Voltage DC circuit power. Supply power is from 12 Volt vehicle battery, suggested to be fused at 0.5 AMPS. Additional suggestions are a 0.5-AMP FUSE for the FUEL Gauge +12V power line. This practice of adding the fuse(s) limits the overall current supplied to the total measurement circuit in case of multiple fault conditions.

## 3.0 SPECIFICATIONS

**Enclosure:** IP54/65 (NEMA 4/5 Dust & Moisture proof) Polystyrene with cover, 4 knockout (1/2-NPT) sidewall conduit entries. Four (4) mounting hole locations, 1.97" (50mm) square centers for #10 screws (not included).

**Conduit Entry:** Four (4), knock-out 1/2" NPT.

**Power Input:** 12VDC (+/- 20%)

**Supply Current:** Approx: 120mA (FULL condition with FUEL Gauge attached)

**Output:** Current sinking (mA), Transistor drive (33~240 ohm FUEL Gauge)

**Temperature Range:** -40 to +158F (-40 to 70C)

**Connections:** three (3) wire, +12 VDC, GROUND & GAUGE (Sender).

**Sensor Probe:** Supplied by user; 60 GAL & 100 GAL

**FUEL GAUGE:** SSU is calibrated to be compatible with supplied Automotive type, 33~240-ohm Input Fuel-Gauge ONLY. 12 VDC, Negative ground. (24VDC option provided with 100-ohm 2W resistor in series with power to 12V type fuel-gauge).

## **Area Classification: General Purpose**

### **4.0 INITIAL SET-UP:**

Control should be permanently mounted to a solid location, using the 4 chassis mounting holes, #10 screw, 1.97" (50mm) centers. Mounting holes located by removing the cover. Location should be isolated from debris and direct weather.

### **5.0 WIRING** (12VDC / 24VDC depending on model / Fuel-Gauge voltage)

Appropriate wiring procedures should be followed per local codes.

- 1) +12/24 Volts DC: From (+ POSITIVE) battery of vehicle. FUSE at 0.5 AMP.
- 2) GROUND: Connect to vehicle chassis / NEG terminal of battery.
- 3) GAUGE: Connect to "SENDER" terminal of FUEL GAUGE.
- 4) Plug probe into mating connector (BNC-type jack).

### **6.0 CALIBRATION: (USING PUSH-BUTTONS)**

Module is calibrated to the Probe & Cable length, as well as to FUEL-GAUGE tolerances. Calibration of each level should only be performed when tank is confirmed EMPTY & FULL. Calibration performed when tank level is unknown and can cause erratic readings and non-linear operation, therefore is not advised.

***Always confirm Tank level is completely EMPTY prior to EMPTY calibration.***

#### **EMPTY TANK CALIBRATION MODE**

1. Disconnect Power to Sending Module.
2. While depressing both PUSH-BUTTONs, apply Power to module.
3. Wait ~2 seconds, then release both PUSH-BUTTONs.
4. RED LED will begin to blink confirming the EMPTY Calibration mode.

#### **FUEL-GAUGE "E" (EMPTY) \* CONFIRM FUEL TANK IS EMPTY\***

1. Read FUEL-GAUGE to determine that needle is positioned to "E".
2. To DECREASE needle value, Depress & hold PUSHBUTTON for RED LED
3. To INCREASE needle value, Depress & hold PUSHBUTTON for GREEN LED
4. Needle will decrease / increase (slowly) while either button is held.
5. Release PUSH-BUTTON when desired needle position is achieved.

#### **EXIT EMPTY CALIBRATION MODE**

1. Depress & hold both PUSH-BUTTONs, wait ~2 seconds, then release.
2. GREEN LED should remain "ON" if EMPTY calibration values were captured.
3. Calibration values are now stored to represent an EMPTY tank, and will correctly display "E" for EMPTY tank.

## **FULL TANK CALIBRATION MODE**

***Always confirm Tank level is completely FULL prior to FULL calibration.***

1. Disconnect Power to Sending Module.
2. While depressing the GREEN LED PUSH-BUTTON, apply Power to the module.
3. Wait ~2 seconds, then release PUSH-BUTTON.
4. GREEN LED will begin to blink, confirming the FULL Calibration mode.

## **FUEL-GAUGE “F” (FULL) Confirm Tank LEVEL IS FULL**

1. Read FUEL-GAUGE to determine that needle is positioned to “F”.
2. To DECREASE needle value, Depress & hold PUSHBUTTON for RED LED
3. To INCREASE needle value, Depress & hold PUSHBUTTON for GREEN LED
4. Needle will decrease / increase (slowly) while either button is held.
5. Release PUSH-BUTTON when desired needle position is achieved.

## **EXIT FULL TANK CALIBRATION MODE**

1. Depress & hold both PUSH-BUTTONS, wait ~2 seconds, then release.
2. GREEN LED should remain “ON” if FULL calibration values were captured.
3. Calibration values are now stored & calibrated to represent a FULL tank, and will correctly display “F” for a FULL tank.

## **IMPROPER CALIBRATION DIAGNOSTIC LED’s**

Empty level calibration value must always be less than FULL level calibration value. Both RED & GREEN LED’s will turn ON & remain ON, if the FULL calibration value is less or equal to the EMPTY value. To clear this error, simply calibrate the FULL level (with the tank FULL) to clear this error..

## **OPTIONAL SERIAL-PORT CALIBRATION COMMANDS (Must request software)**

Type in exactly as displayed (lower-case).

### Read-Only Commands

- Voltage (Output voltage to amplifier / Read Only)
- Frequency (Present frequency measured at probe / Read Only)

Calibration Values (EEPROM Stored): Use underscore no\_space when typing commands

- empty\_voltage (Voltage stored for EMPTY Calibration)
- empty\_frequency (Frequency represents EMPTY Tank)
- full\_voltage (Voltage Represents FULL-Tank)
- full\_frequency (Frequency Represents FULL-Tank)

PROBE / BNC

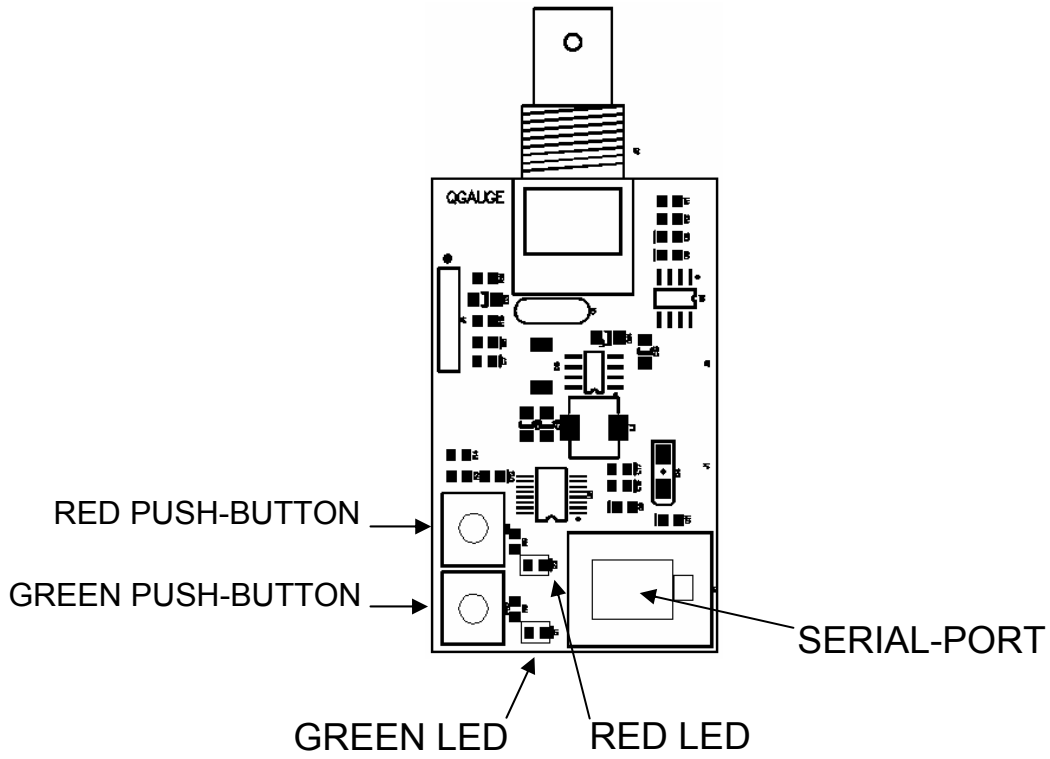

## 7.0 TROUBLESHOOTING

- Verify input power with an accurate voltmeter. The accepted tolerance is  $\pm 20\%$  of specified Voltage (depending on model).
- Range / adjustment error: Verify total Probe cable length is within specified limits. Verify EMPTY-FULL calibration is correct..
- Confirm sensor probe is properly connected. (no kinks, shorts or breaks in the coax cable).
- Disconnect the probe; FUEL Gauge should fall to EMPTY lower-limit condition.
- A shorted probe / cable will display a FULL Range Gauge condition.
- Simulate FULL Gauge condition by adding approximately 50 pico-Farads of capacitance to probe circuit.

Typical Capacitance change between EMPTY & FULL is around 50pF. Exact value will have to be measured by connecting a Capacitance METER to the probe terminals (remove probe from Sender unit)

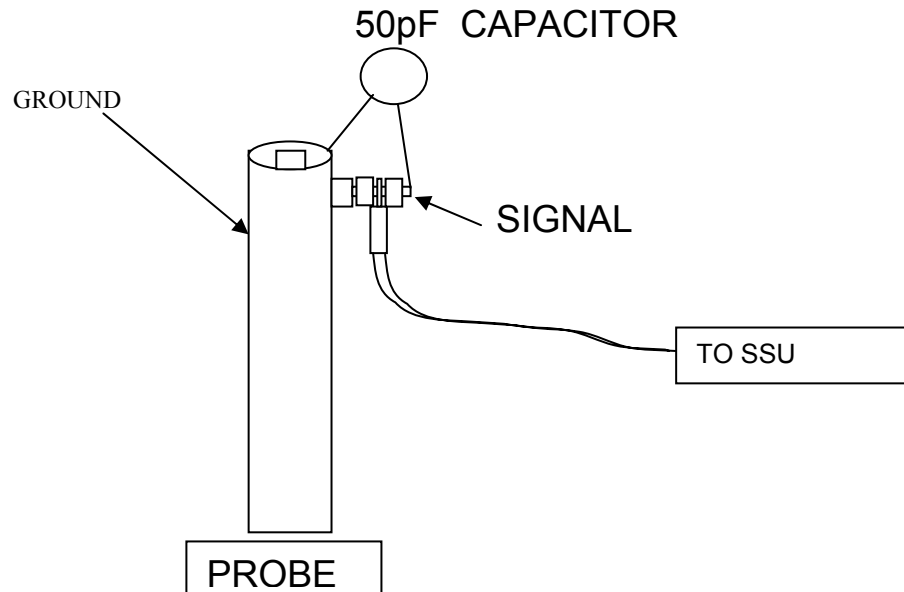

## TROUBLESHOOTING (CONT)

Connecting a capacitance probe in place of the SSU, and measuring the capacitance value directly from the probe is possible using a Capacitance METER. Value will be in the hundreds of Pico-Farads  $1 \times 10^{-12}$ , and many things can affect the value (temperature, probe wire length, etc). Below are typical values.

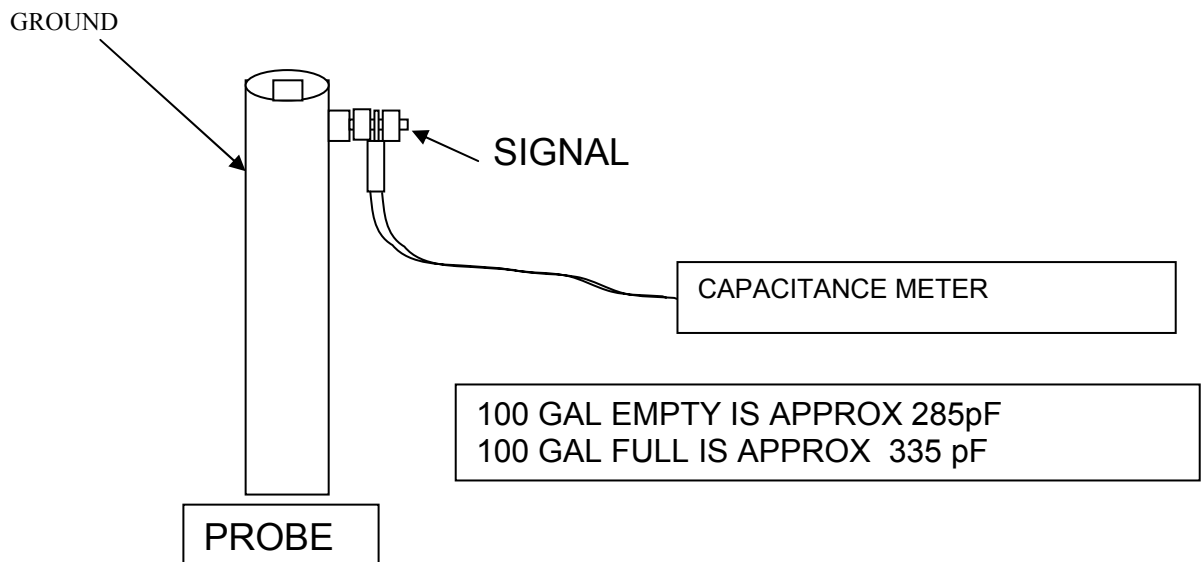

### 8.0 **ASSISTANCE**

If you encounter problems after reviewing the manual, contact your supplier or Distributor of this product. Please have your model-number available.

### 9.0 **WARRANTY & PARTS**

Refer to the Manufacturer's General Terms and Conditions of Sales for warranty information. Contact your supplier or Distributor of this product. Please have your model-number available.

## 10.0 DRAWINGS

Refer to the following pages for reference locations and hook-up details.

FUEL GAUGE CONNECTION:

12VDC: CONNECT VEHICLE POWER TO I (SWITCHED IGNITION) AND GROUND

24VDC: A WIRING HARNESS IS PROVIDED WITH A 100-OHM 2W RESISTOR IN SERIES WITH GAUGE POWER (I), FOR COMPATIBILITY WITH 24VDC POWER.

CONNECT (S) TO SENDER (GREEN WIRE) FOR LEVEL SIGNAL.

LAMP PROVIDED IS 12VDC OR 24VDC / DEPENDING ON MODEL ORDERED

### FUEL-GAUGE WIRING

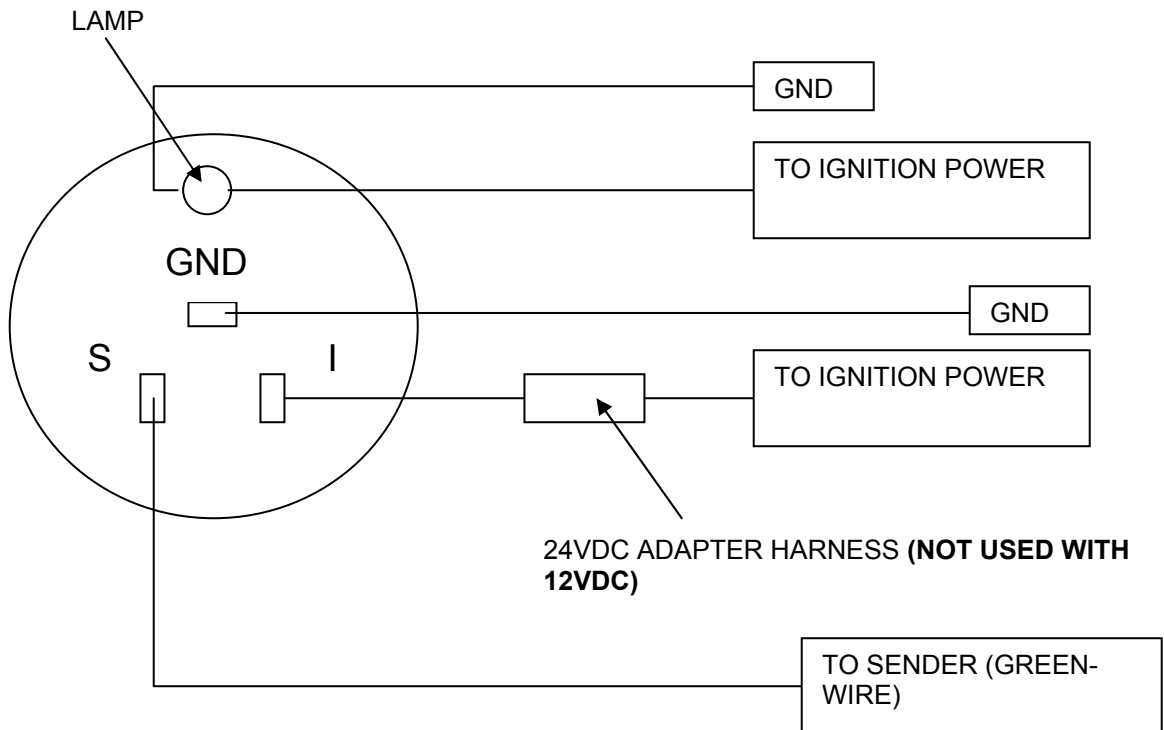

REPLACEMENT LAMP:  
12VDC: C161 (2W)  
24VDC C657 (2W)

REVISIONS	DATE	CK'D	APP

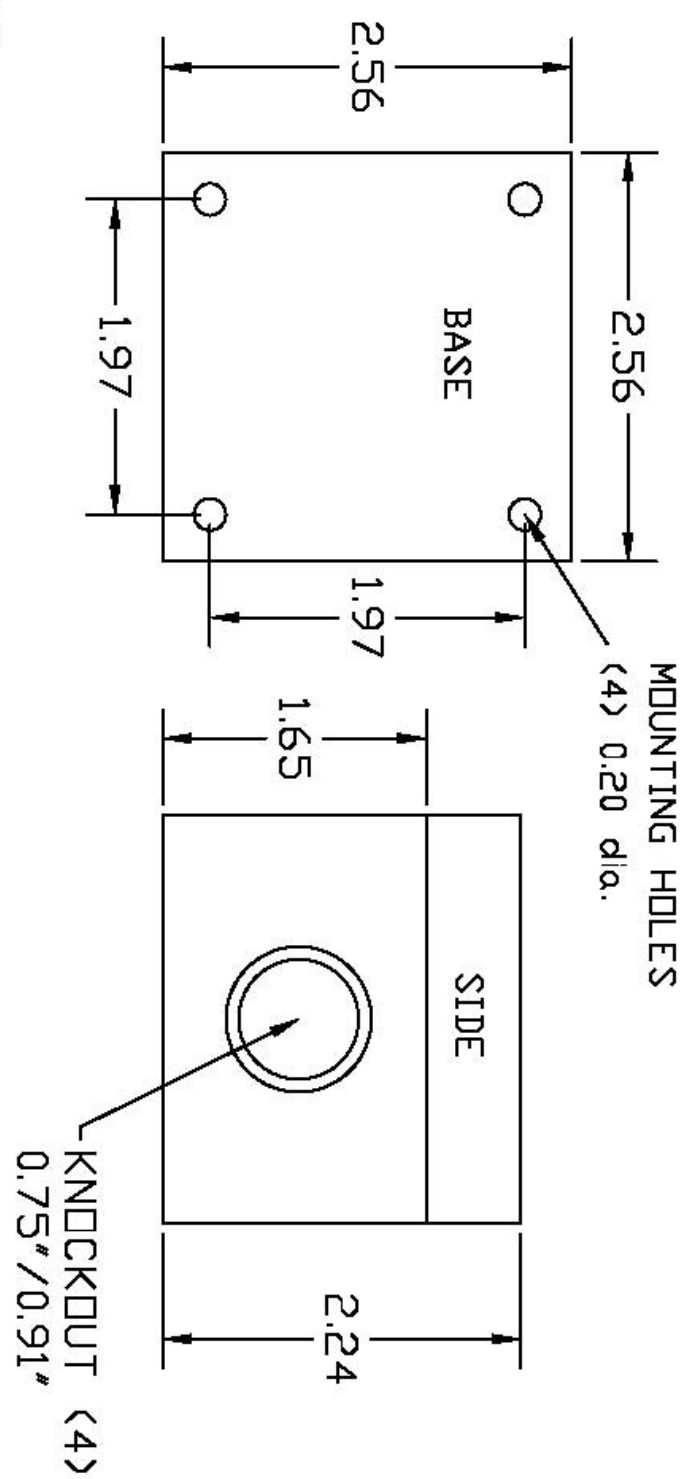

NOTES:  
ENCLOSURE = ALTECH TK77  
POLYSTYRENE NEMA 4X  
LIGHT GRAY COLOR  
-40F - 158F

DO NOT SCALE  
DIMENSIONS ARE IN INCHES

MATERIAL	FINISH	DET.	REQ'D	SHT	DESCRIPTION	MAT. DR PAR
HEWTECH ELECTRONICS CHINA, MICHIGAN 48054		UNSPECIFIED TOL. DECIMAL SIZE ± ANGLES ±1/2° HOLE DR & BREAK FINISH PER			DRAWN HEWELLT DATE 9/07/02	DATE
					CHECKED	DATE
					APPROVED	DATE
					PREVIOUS	DATE
					SIZE	PART OR DRAWING
					SCALE	
					NEXT ASS'Y	
					TITLE	
					LNG QUANTITY GAUGE	
					SHEET	OF